



FILTERS

FLOW MANAGEMENT SOLUTIONS Division



Manual Filters

- Fluid filtration under vacuum or pressure for equipment protection.
- Low price, easy assembly and little maintenance.
- Material range: carbon steel, stainless steel and other materials upon request.
- Fluids: water, oil, coolants, fuel, gases, etc.

Y Strainer



Forged

Sizes: 1/2"-2".

NPT, SW and BW connections → ratings 800#-1500#.

Flanged connections → ratings 150#, 300# and 600#.



Casted

Pressure range: PN16-PN40 / 150#-300#.

NPT and BSP connections → sizes 1/2"-4".

Flanged connections → sizes DN15-DN250 / 1/2"-10".



Fabricated

Sizes: DN125-DN600 / 5"-24".

Pressure range: PN16-PN40 / 150#-300#.

Flanged connections DIN/ANSI RF.

Other sizes and pressure ratings available upon request.

T Strainer



Size range: 2"-24".

Pressure ratings: 150#-300#.

Flanged or BW connections.

Temporary Strainer



Type: conical / tronco-conical.

Size range: DN40-DN600 / 1 1/2"-24".

Pressure range: PN10-PN40 / 150#-600#.

Straight /Angular filter



Size range: DN25-DN100.

Material: 304L / 316L.

Standard water application Strainer



Size range: 2"-20".

Material: carbon steel.

Centrifugal separator

Used to reduce the quantity of suspended solids.

98% of the particles larger than 75 µm are removed thanks to the centrifugal force.

Flowrate range: from 0.7 m³/h to 2700 m³/h.

Materials: carbon steel, stainless steel and polyethylene (PE-HD).





Manual Filters

Simplex and Duplex basket filter

- Higher mesh area and lower pressure drop than the “Y” Strainers.
- Duplex configuration allows maintenance without line interruption.
- Fineness from 50 µm.



Casted

Pressure range: PN6-PN16.

Sizes: DN25-DN300.

Connections: flanged or threaded.

Materials: cast iron, carbon steel or bronze.



Fabricated

Sizes: DN125-DN400 / 5”-16”.

Pressure rating: PN16 / 150#.

Connections: DIN/ANSI RF.

Materials: carbon steel or stainless steel.

Other sizes and pressure ratings upon request.

Possibility of manufacturing any configuration under customer’s specifications.

Cartridge filter

- Housing in stainless steel 316L.
- Cartridges 100% in polypropylene.
- Nominal pressure: 10 bar.
- Fineness from 0.1 µm.
- Applications: food, cosmetics, pharmacy, water treatment and general industry.



Industrial line



Sanitary line

Bag filter

- Housing in stainless steel 316L.
- Bags in polypropylene or polyester.
- Nominal pressure: 10 bar.
- Fineness from 1 µm.
- Applications: liquids with high solids concentration or high viscosity (paints, creams, varnishes, oils...)





Self-cleaning Filters

- Liquid filtration without interrupting the flowrate while cleaning the filter element.
- High filtration efficiency and very little maintenance.
- Pressure range: PN10-PN16.
- Sizes: DN25-DN1800.

Bernoulli self-cleaning filters

- Continuous filtration. Cleaning based in the Bernoulli principle, which relates pressure and velocity.
- Fluids: fresh water, salt water or any watery liquid.
- Excellent for high flowrates and high levels of suspended solids (up to 200 mg/L).
- Cleaning system activated by differential pressure or by time interval.
- High filtration efficiency and very low pressure drop.
- Minimum operation pressure required: 0.6 bar.
- Sizes: DN65-DN1800.
- Fineness from 150 μm .
- Positioning in vertical, horizontal or diagonal orientation.
- Body materials: carbon steel, stainless steel, GRP or bronze.
- Mesh and internal parts material: stainless steel, Duplex or SuperDuplex.

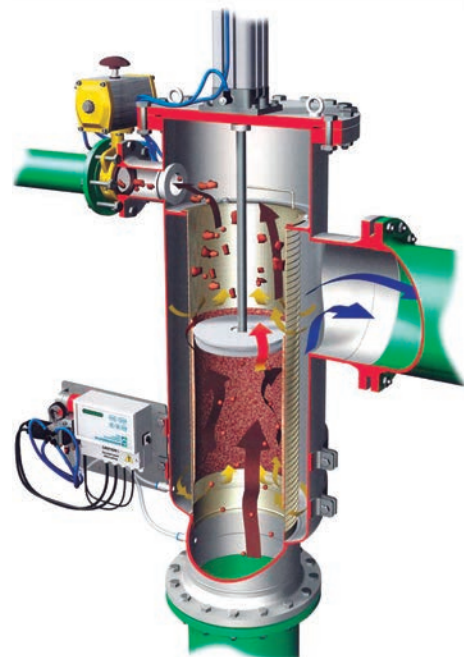



Self-cleaning Filters

Backflushing self-cleaning filters

- Cleaning is done by suction nozzles through the entire screen.
- Fluids: fresh water, salt water or any watery liquid.
- Cleaning system activated by differential pressure or by time interval.
- Minimum operation pressure required: 2.5 bar.
- Sizes: DN80-DN350.
- Fineness from 125 µm.
- Body in carbon steel and screen in stainless steel.



Blade-type self-cleaning filters

- Cleaning produced by a couple of scraper blades against the screen.
- Fluids: water, oil, fuels, resins, paints. Suitable for high viscosity liquids.
- Cleaning system manually activated (through a handle) or automatically activated (by differential pressure or interval).
- Sizes: DN50-DN300.
- Fineness from 50µm.
- Body and internal parts in stainless steel.
- Heated jacket units for high-temperature applications.
- Rental units available.



Backwashing self-cleaning filters

- Manual or automatic cleaning, by differential pressure or time interval.
- Fluids: water or any watery liquid. Approved for drinking water.
- Threaded connections (1"-2") or flanged connections (DN65-DN200).
- Fineness from 30 µm.
- Minimum required operation pressure: 1 bar.
- Body in carbon steel Rilsan coated and mesh in stainless steel.



Disc filters

- Automatic cleaning by differential pressure.
- Fluids: fresh water and salt water.
- Modular design from DN50. Suitable for high flowrates.
- Fineness from 5 µm.
- Body in polyamide. Discs in polypropylene.





OTHER APPLICATIONS

Membrane filtration

- **Types:**
 - Microfiltration.
 - Ultrafiltration.
 - Nanofiltration.
 - Reverse Osmosis.
- **Applications:** desalination pretreatment, water purification, waste treatment, etc.



Gas transfer

- **Applications:** all areas involved in the gas network (reception plant, high pressure network, low pressure local network).
- **Materials:** carbon steel, stainless steel, duplex and other non-ferrous alloys.
- **Types of equipment:** S-type filters, T-type filters, J-type filters, H-type filters, coalescer filters (horizontal, vertical, cyclone type, ...).
- **Pressure range up to 150 bar.**

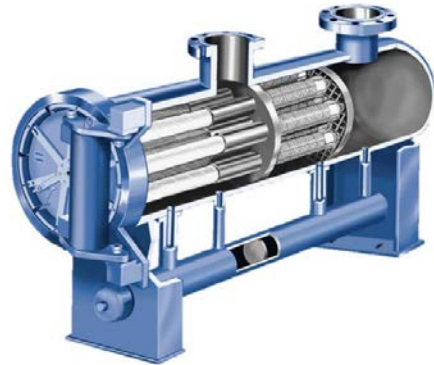

Dust collection

- **Equipment type:** complete system of dust removal through bags or cartridges. Design according to customer's necessity. Minimum maintenance guaranteed.
- **Applications:** wood industry, paint industry, metal industry, etc. Valid also for ATEX atmosphere.

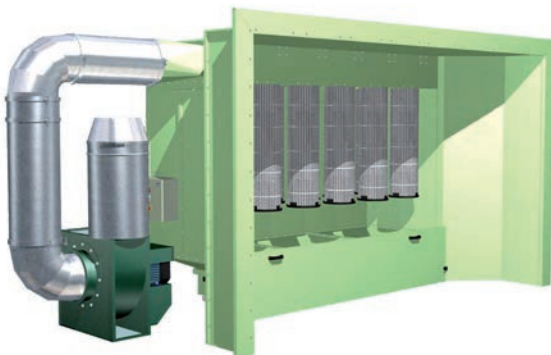



MAIN REFERENCES

CUSTOMER	FILTER TYPE	PROJECT / REFERENCE	COUNTRY
ABANTIA	SIMPLEX BASKET FILTERS	PRODUCTION PLANT IN BARCELONA	SPAIN
ABELLO LINDE	SELF-CLEANING FILTERS	PRODUCTION PLANT IN SALAMANCA	SPAIN
ABENGOA	SELF-CLEANING FILTERS	QINGDAO DESALINATION PLANT	CHINA
ABENGOA	SELF-CLEANING FILTERS	AGADIR DESALINATION PLANT	MOROCCO
ABENGOA	SELF-CLEANING FILTERS	BARKA DESALINATION PLANT	OMAN
ANDRITZ HYDRO	SELF-CLEANING FILTERS	RENACE HYDROPOWER PLANT	GUATEMALA
ANDRITZ HYDRO	SELF-CLEANING FILTERS	MONTE LIRIO HYDROPOWER PLANT	PANAMA
ARANER	CENTRIFUGAL SEPARATORS	ARAMCO'S THIRD PARTY COGENERATION	SAUDI ARABIA
ARCELORMITTAL	"Y" STRAINERS	PRODUCTION PLANT IN ZARAGOZA	SPAIN
BONATTI	"T" STRAINERS	OURHOUD OIL & GAS PLANT	ALGERIA
CEPSA	"T" STRAINERS	SAN ROQUE REFINERY	SPAIN
COBRA INGENIERIA	"Y" STRAINERS	SAN PEDRO BIOMASS PLANT	DOMINICAN REPUBLIC
DURO FELGUERA	"T" , BASKET AND CONICAL STRAINERS	NAFTAN REFINERY	BELARUS
EON GENERATION	SELF-CLEANING FILTERS	ALGECIRAS COMBINED CICLE PLANT	SPAIN
FLOWSERVE	BASKET FILTERS	MAE MOH POWER PLANT	THAILAND
FLOWSERVE	CENTRIFUGAL SEPARATORS	QURAYYAH COMBINED CICLE PLANT	SAUDI ARABIA
IBERDROLA	DUPLEX BASKET FILTERS	CAÑAVEROSA PLANT	SPAIN
ISOLUX CORSAN	SELF-CLEANING FILTERS	MANSOUR EDDAHBI HYDROPOWER PLANT	MOROCCO
OHL INDUSTRIAL	BASKET FILTERS	AMMAN OIL TERMINAL	JORDAN
PEMEX	"Y" STRAINERS	CADEREYTA REFINERY	MEXICO
REPSOL	"Y" STRAINERS	PUERTOLLANO REFINERY	SPAIN
SPONTEX	SELF-CLEANING FILTERS	PRODUCTION PLANT IN BARCELONA	SPAIN
TECNICAS REUNIDAS	"T" AND CONICAL STRAINERS	JAZAN REFINERY	SAUDI ARABIA
YPFB REFINACION	"Y" STRAINERS	COCHABAMBA REFINERY	BOLIVIA



Calle Camino del Olivar, 2 (Esquina Calle México)
28806 Alcalá de Henares, Madrid (SPAIN)
Tel: (+34) 91 887 87 00 - Fax: (+34) 91 887 87 33
info@grupocunado.com - www.grupocunado.com

SPAIN

ANDALUCIA: SEVILLA & ALGECIRAS (+34) 955.63.06.12 - andalucia@grupocunado.com
ARAGON: ZARAGOZA (+34) 976.18.52.58 - aragon@grupocunado.com
CANARIAS: LAS PALMAS (+34) 928.70.05.00 - canarias@cunado.com
CASTILLA LA MANCHA: PUERTOLLANO (+34) 926.46.00.55 - clm@cunado.com
CASTILLA Y LEON: ventascastillaleon@cunado.com
CATALUÑA: BARCELONA, GERONA & TARRAGONA (+34) 93.575.24.24 - cataluna@grupocunado.com
GALICIA: VIGO (+34) 986.34.26.06 - galicia@cunado.com
LEVANTE: VALENCIA & CARTAGENA (+34) 96.181.92.00 - levante@grupocunado.com
MADRID: (+34) 91.887.87.00 - madrid@grupocunado.com
NORTE: BILBAO & GIJON (+34) 94.453.31.54 - norte@grupocunado.com

INTERNATIONAL

CTA, LDA. (PORTUGAL): (+351) 217.995.280 - info@cta.pt
CUINTER (CHILE): (+56) 2.2787.0300 - mail@cunado.cl
CUÑADO ABU DHABI: info.abudhabi@grupocunado.com
CUÑADO ASIA CORPORATION (CHINA): (+86) 21.2024.8130 - info@cunadoasia.com
CUÑADO SINGAPUR: info@grupocunado.com
CUÑADO BOLIVIA: (+591) 3.3110683 - bolivia@grupocunado.com
CUÑADO CANADA: info.canada@grupocunado.com
CUÑADO COLOMBIA: (+51) 320.532.2498 - info.colombia@grupocunado.com
CUÑADO DUBAI (UAE): info.dubai@grupocunado.com
CUÑADO FRANCE: info.france@grupocunado.com
CUÑADO MEXICO: (+52) 55.5254.04.05 - cumex@prodigy.net.mx
CUÑADO THAILAND: (+66) 909 206 134 - stephane.trabbia@grupocunado.com
CUPERSA (PERU): (+511) 416 62 00 Anexo 101 - info@grupocunado.pe
CUÑADO CENTRAL EUROPE (GERMANY): (+49) 7254 9271 0 - info@flaboform.de
CUÑADO POLAND: (+48) 32 32913 68 - info@flaboform.pl
CUÑADO CZECH REP.: info@flaboform.cz
ITF, INC. (USA): (+1) 713.952.4111 - itfinc@cunadousa.com
OMEGA INDUSTRIAL (USA): (+1) 225.749.9808 - info@omega-industrial.com
RAGENSA (PERU): (+511) 416 62 00 Anexo 101 - info@grupocunado.pe



www.grupocunado.com